

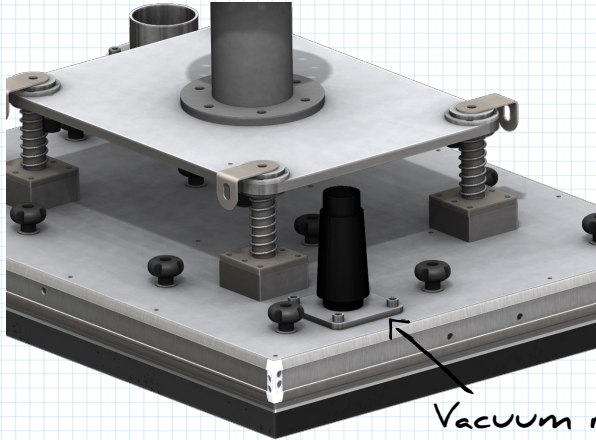

# Relief Valves

Even though the main element for creating the UniGripper power is air, this element has to be handled with care. By creating too large pressure differences, the handled product, the UniGripper or the vacuum creation unit can get damaged. We therefore often include relief valves, both for vacuum and (over) pressure.



## *Air intake*

The vacuum relief valve becomes an air inlet when the vacuum pressure exceeds a specific level. This ensures that the vacuum pressure does not increase further and protects the vacuum creation unit from over heating. Too high vacuum pressure can also make the lifted products implode, which is another reason to use this valve.

## *Air outlet*

The pressure relief valve becomes an air outlet when the the pressure exceeds a specific level. This can happen when reverse blowing through the UniGripper and can damage the suction foam or the handled products.

